

SG/PG Series

GENERAC[®]

**INDUSTRIAL
POWER**

50 Hz

250 kVA

Industrial Spark-Ignited Generator Set

Generac International Products

12.9L

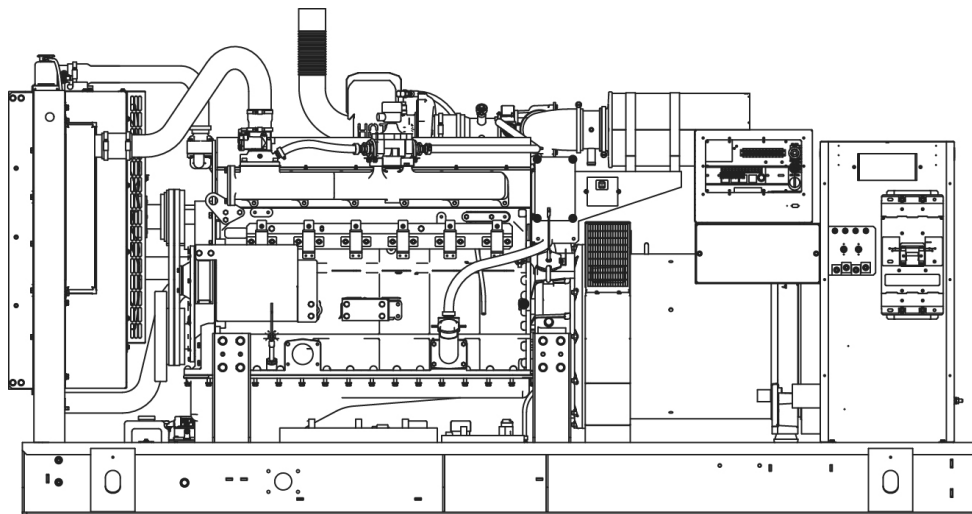

Image used for illustration purposes only

Standby Rated Generators		
Standby	SG200	250 kVA / 200 kW
Prime	PG160	200 kVA / 160 kW

Prime and standby ratings based on 3-Phase voltages. Model number based on kW rating.

Powering Ahead

For over 50 years, Generac has provided innovative design and superior manufacturing.

Generac ensures superior quality by designing and manufacturing most of its generator components, including alternators, enclosures and base tanks, control systems and communications software.

Generac's gensets utilize a wide variety of options, configurations and arrangements, allowing us to meet the standby power needs of practically every application.

Generac searched globally to ensure the most reliable engines power our generators. We choose only engines that have already been proven in heavy-duty industrial applications under adverse conditions.

Generac is committed to ensuring our customers' service support continues after their generator purchase.

50 Hz SG/PG Series

Standard Features

ENGINE SYSTEM

General

- Oil Drain Extension
- Air Cleaner
- Fan Guard
- Stainless Steel flexible exhaust connection
- Critical Exhaust Silencer (enclosed only)
- Factory Filled Oil

Fuel System

- Primary and Secondary Fuel Shutoff
- Flexible Fuel Line - NPT Connection

Cooling System

- Closed Coolant Recovery System
- UV/Ozone resistant hoses
- Factory-installed Radiator
- 50/50 Ethylene glycol antifreeze

Engine Electrical System

- Battery charging alternator
- Battery Cables
- Battery Tray
- Solenoid activated starter motor
- Rubber-booted engine electrical connections

ALTERNATOR SYSTEM

- Class H insulation material
- 2/3 Pitch
- Skewed Stator
- Permanent Magnet Excitation
- Sealed Bearings
- Amortisseur winding
- Full load capacity alternator

GENERATOR SET

- Internal Genset Vibration Isolation
- Separation of circuits - high/low voltage
- Separation of circuits - multiple breakers
- Wrapped Exhaust Piping (enclosed only)
- Standard Factory Testing
- 2 Year Warranty (Standby rated units)
- 1 Year Warranty (Prime rated units)
- Silencer mounted in the discharge hood (enclosed only)

ENCLOSURE

- Rust-proof fasteners with nylon washers to protect finish
- High performance sound-absorbing material
- Gasketed doors
- Stamped air-intake louvers
- Air discharge hoods for radiator-upward pointing
- Stainless steel lift off door hinges
- Stainless steel lockable handles
- Rhino Coat™ - Textured polyester powder coat

CONTROL SYSTEM



Control Panel

- Digital H Control Panel - Dual 4x20 Display
- Programmable Crank Limiter
- 7-Day Programmable Exerciser
- Special Applications Programmable PLC
- RS-232/485
- All-Phase Sensing DVR
- Full System Status
- Low Fuel Pressure Indication
- 2-Wire Start Compatible
- Power Output (kW)
- Power Factor
- kW Hours, Total & Last Run
- Real/Reactive/Apparent Power
- All Phase AC Voltage
- All Phase Currents

- Oil Pressure
- Coolant Temperature
- Coolant Level
- Engine Speed
- Battery Voltage
- Frequency
- Date/Time Fault History (Event Log)
- Isochronous Governor Control
- Waterproof/sealed Connectors
- Audible Alarms and Shutdowns
- Not in Auto (Flashing Light)
- Auto/Off/Manual Switch
- E-Stop (Red Mushroom-Type)
- Customizable Alarms, Warnings, and Events
- Modbus protocol
- Predictive Maintenance algorithm
- Sealed Boards
- Password parameter adjustment protection
- Single point ground
- 15 channel data logging
- 0.2 msec high speed data logging
- Alarm information automatically comes up on the display

Alarms

- Oil Pressure (Pre-programmable Low Pressure Shutdown)
- Coolant Temperature (Pre-programmed High Temp Shutdown)
- Coolant Level (Pre-programmed Low Level Shutdown)
- Low Fuel Pressure Alarm
- Engine Speed (Pre-programmed Over speed Shutdown)
- Battery Voltage Warning
- Alarms & warnings time and date stamped
- Alarms & warnings for transient and steady state conditions
- Snap shots of key operation parameters during alarms & warnings
- Alarms and warnings spelled out (no alarm codes)

SG/PG Series

Configurable Options

ENGINE SYSTEM

- General
- Engine Block Heater
- Air Filter Restriction Indicator
- Stone Guard (Open Set Only)
- Critical Exhaust Silencer (Open Set Only)
- Engine Electrical System
- 10A battery charger

ALTERNATOR SYSTEM

- Alternator Upsizing
- Anti-Condensation Heater
- Tropical coating

GENERATOR SET

- Gen-Link Communications Software (English Only)
- Extended Factory Testing (3 Phase Only)
- Pad Vibration Isolators
- 150 MPH Wind Kit

CIRCUIT BREAKER OPTIONS

- Main Line Circuit Breaker
- 2nd Main Line Circuit Breaker
- Shunt Trip and Auxiliary Contact
- Electronic Trip Breakers

ENCLOSURE

- Weather Protected
- Level 1 Sound Attenuation
- Level 2 Sound Attenuation
- Steel Enclosure
- Aluminum Enclosure
- 12 VDC Enclosure Lighting Kits
- Door Alarm Switch

CONTROL SYSTEM

- 21-Light Remote Annunciator
- Remote Relay Panel (8 or 16)
- Oil Temperature Sender with Indication / Alarm
- Remote E-Stop (Break Glass-Type, Surface Mount)
- Remote E-Stop (Red Mushroom-Type, Surface Mount)
- Remote E-Stop (Red Mushroom-Type, Flush Mount)
- Remote Communication - Modem
- 10A Run Relay

Engineered Options

ENGINE SYSTEM

- Coolant heater ball valves
- Fluid containment pans

ALTERNATOR SYSTEM

- 3rd Breaker Systems

GENERATOR SET

- Special Testing
- Battery Box

ENCLOSURE

- Motorized Dampers

CONTROL SYSTEM

- Spare inputs (x4) / outputs (x4) - H Panel Only
- Battery Disconnect Switch

Rating Definitions

Standby – Applicable for a varying emergency load for the duration of a utility power outage with no overload capability. (Max. load factor = 70%)

Prime – Applicable for supplying power to a varying load in lieu of utility for an unlimited amount of running time. (Max. load factor = 70%) A 10% overload capacity is available for 1 out of every 12 hours. The Prime Power option is only available on International applications.

Power ratings in accordance with ISO 8528-1, Second Edition dated 2005-06-01, definitions for Prime Power (PRP) and Emergency Standby Power (ESP).

ENGINE SPECIFICATIONS
General

Make	Generac
Cylinder #	6
Type	Inline
Displacement - L (Cu. In.)	12.88
Bore - mm (in.)	135 (5.31)
Stroke - mm (in.)	150 (5.91)
Compression Ratio	10.92:1
Intake Air Method	Turbocharged/Aftercooled
Number of Main Bearings	7
Connecting Rods	Carbon Steel
Cylinder Head	Cast Iron GT250, OHV
Cylinder Liners	Ductile Iron
Ignition	Altronic CD1
Pistons	Aluminum
Crankshaft	Ductile Iron
Lifter Type	Solid
Intake Valve Material	Special Heat-Resistant Steel
Exhaust Valve Material	Allow Steel, High Temp
Hardened Valve Seats	Allow Steel, High Temp

Lubrication System

Oil Pump Type	Gear
Oil Filter Type	Full-flow spin-on cartridge
Crankcase Capacity - L (qts)	34.3 (36.2)

Cooling System

Cooling System Type	Pressurized Closed Recovery
Water Pump Flow	65 gal/min
Fan Type	Pusher
Fan Speed (rpm)	1580
Fan Diameter mm (in.)	762 (30)
Optional Coolant Heater Wattage	2000
Optional Coolant Heater Voltage	240 V

Fuel System

Fuel Type	Natural Gas
Carburetor	Down Draft
Secondary Fuel Regulator	Standard
Fuel Shut Off Solenoid	Standard
Operating Fuel Pressure	11" - 15" H2O

Engine Electrical System

System Voltage	24 VDC
Battery Charging Alternator	Std
Min. Recommended Battery Size	1155 CCA
Battery Voltage	(2) 12 VDC
Ground Polarity	Negative

ALTERNATOR SPECIFICATIONS

Standard Model	520mm
Poles	4
Field Type	Revolving
Insulation Class - Rotor	H
Insulation Class - Stator	H
Total Harmonic Distortion	<5%
Telephone Interference Factor (TIF)	<50
Standard Excitation	Permanent Magnet
Bearings	Sealed Ball
Coupling	Direct, Flexible Disc
Prototype Short Circuit Test	Yes

Voltage Regulator Type	Full Digital
Number of Sensed Phases	All
Regulation Accuracy (Steady State)	+/- 0.25%

Engine Governing

Governor	Electronic
Frequency Regulation (Steady State)	+/- 0.25%

250 kVA / 200 kW

operating data

POWER RATINGS – NATURAL GAS

Three Phase 231/400 VAC @0.8pf	Standby		Prime	
	250 kVA / 200 kW	361 Amps	200 kVA / 160 kW	289 Amps

STARTING CAPABILITIES (sKVA)

		sKVA vs. Voltage Dip					
		231/400 VAC					
Alternator	kVA	10%	15%	20%	25%	30%	35%
Standard	250	218	328	437	546	656	765
Upsize 1	300	251	377	502	628	754	879

FUEL CONSUMPTION RATES*

Natural Gas – ft ³ /hr (m ³ /hr)		
Percent Load	Standby	Prime
25%	915 (25.9)	801 (22.7)
50%	1568 (44.4)	1374 (38.9)
75%	2117 (59.9)	1854 (52.5)
100%	2613 (74.0)	2289 (64.8)

*Fuel supply installation must accommodate fuel consumption rates at 100% load.

COOLING

		Standby	Prime
Air Flow (inlet air combustion and radiator)	ft ³ /min (m ³ /min)	8062 (228.3)	8062 (228.3)
System Coolant Capacity	Gal (Liters)	19 (71.9)	19 (71.9)
Heat Rejection to Coolant	BTU/hr	654,209	542,993
Max. Operating Ambient Temperature	°F (°C)	104 (40)	104 (40)
Maximum Radiator Backpressure	in H ₂ O	0.5	0.5

COMBUSTION AIR REQUIREMENTS

		Standby	Prime
Flow at Rated Power	cfm (m ³ /min)	354 (10.0)	333 (9.4)

ENGINE

		Standby	Prime
Rated Engine Speed	rpm	1500	1500
Horsepower at Rated kW	hp	362	290
Piston Speed	ft/min (m/min)	1477(450)	1477(450)
BMEP	psi	215	206

EXHAUST

		Standby	Prime
Exhaust Flow (Rated Output)	cfm (m ³ /min)	1250 (35.4)	1175 (33.3)
Maximum Recommended Back Pressure	inHg	1.5	1.5
Exhaust Temp (Rated Output)	°F (°C)	1334 (723)	1227 (664)
Exhaust Outlet Size (Open Set)	in	3.5" I.D. Flex (No Muffler)	

Deration – Operational characteristics consider maximum ambient conditions. Derate factors may apply under atypical site conditions. Please consult a Generac Power Systems Industrial Dealer for additional details. All performance ratings in accordance with ISO3046, BS5514, ISO8528 and DIN6271 standards. All power ratings are +/- 5%.

SG/PG Series

dimensions and weights

50 Hz

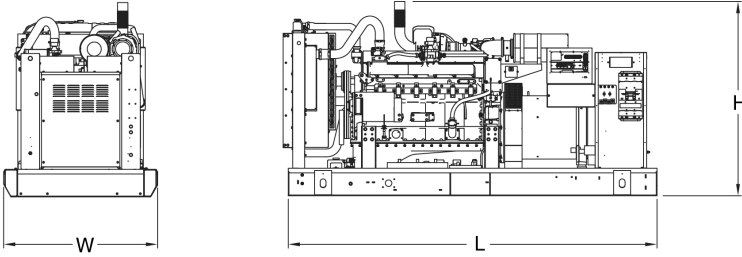

OPEN SET (Includes Exhaust Flex)

L x W x H in (mm)	138.74 (3524.1) x 57.6 (1463.1) x 68.04 (1728.3)
Weight lbs (kg)	6364 (2887)

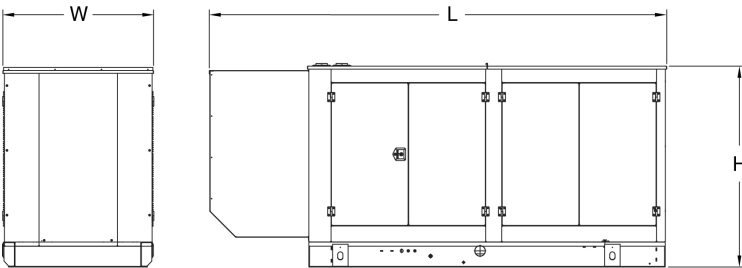

STANDARD ENCLOSURE

L x W x H in (mm)	174.7 (4437.4) x 52.98 (1345.7) x 77.8 (1976.1)
Weight lbs (kg)	Steel: 7538 (3420) Aluminum: 6765 (3069)

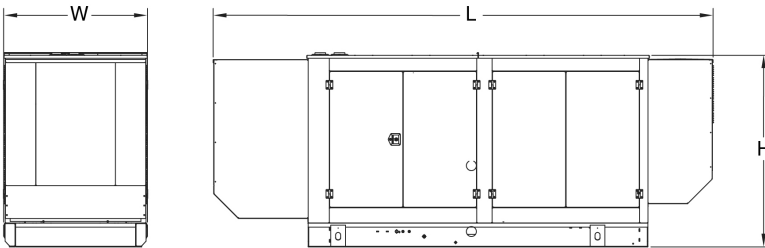

LEVEL 1 ACOUSTIC ENCLOSURE

L x W x H in (mm)	200.19 (5084.7) x 57.49 (1460.4) x 77.80 (1976.1)
Weight lbs (kg)	Steel: 8094 (3672) Aluminum: 6955 (3155)

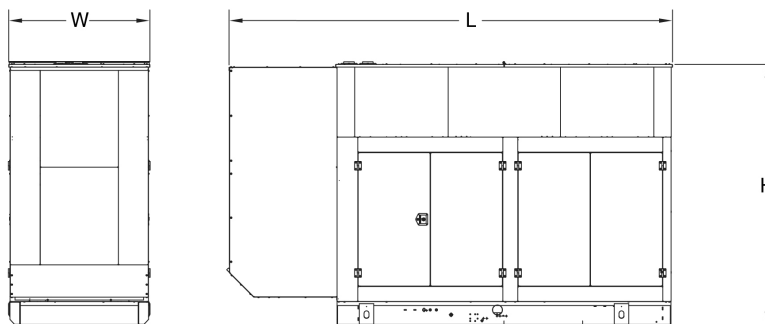

LEVEL 2 ACOUSTIC ENCLOSURE

L x W x H in (mm)	180.65 (4588.4) x 57.49 (1460.4) x 107.3 (2725.4)
Weight lbs (kg)	Steel: 8656 (3927) Aluminum: 7156 (3246)

YOUR FACTORY RECOGNIZED GENERAC INDUSTRIAL DEALER

Specification characteristics may change without notice. Please consult a Generac Power Systems Industrial Dealer for detailed installation drawings.