



SLIMLINE ANGLE HEADS



Ø80

Ø75

184

79



20 Thompson Rd | East Windsor | CT 06088
1.800.249.5662 | 860.623.4132 Fax
www.komaprecision.com | info@komaprecision.com

Dimensional Drawing*

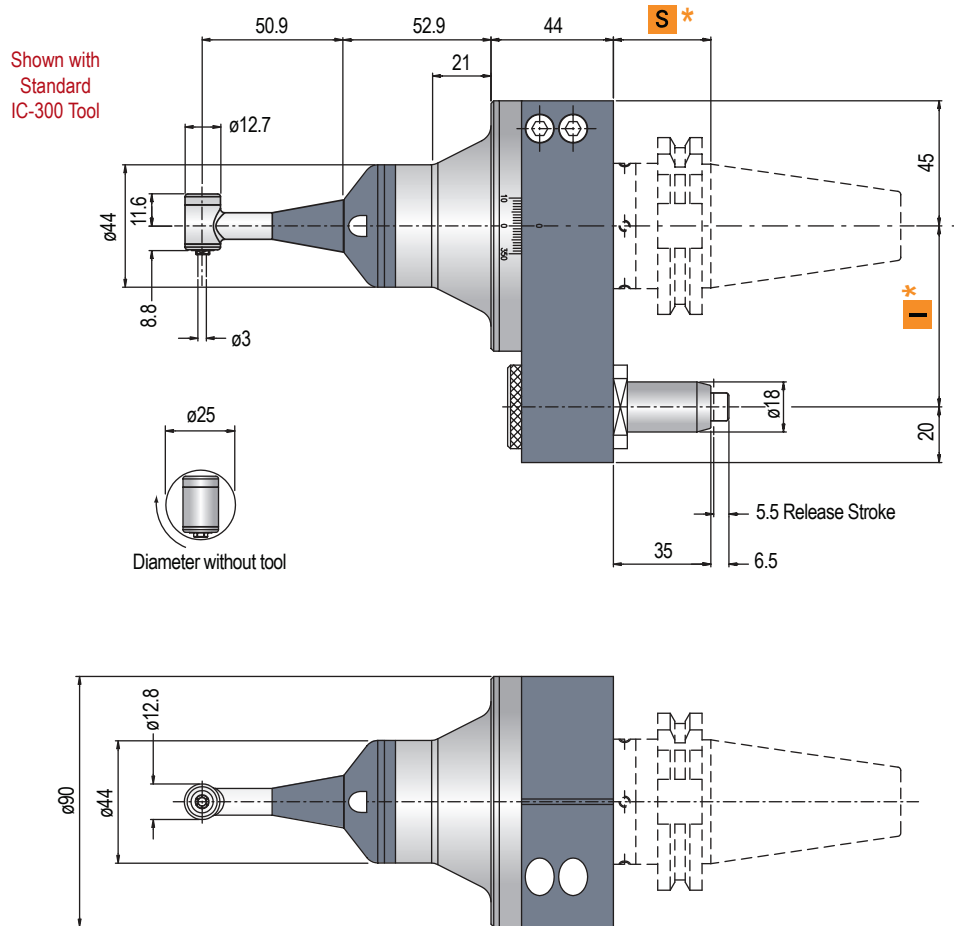

Optional Drive Shanks*

Non interchangeable input drive shank

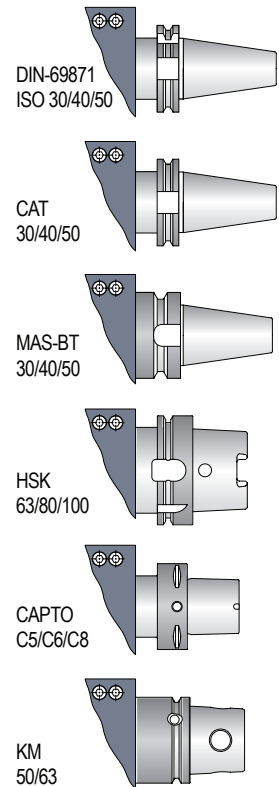

Dimensional Drawing & Optional Drive Shanks*

SHANK	DIN-69871 / CAT			MAS / BT			HSK		CAPTO		KM
Size	30	40	50	30	40	50	63/80	100	C5/C6	C8	50/63
I Arm Length (mm)	65,80	65,80 (110*)	80 (110*)	65,80	65,80 (110*)	80 (110*)	65,80 (110*)	80 (110*)	65,80 (110*)	80 (110*)	65,80 (110*)
S Flange Spacing (mm)	35	35	35	30	35	41	42	45	38	40	40

*optional

Technical Data

T90sl-0.3	
Ratio	1:75
Maximum Input RPM	20,000
Weight	7.7 lbs

Included with Tool: Storage Case • (1) NSK Tool (IC-300) • Wrenches • Grease • Instruction Manual

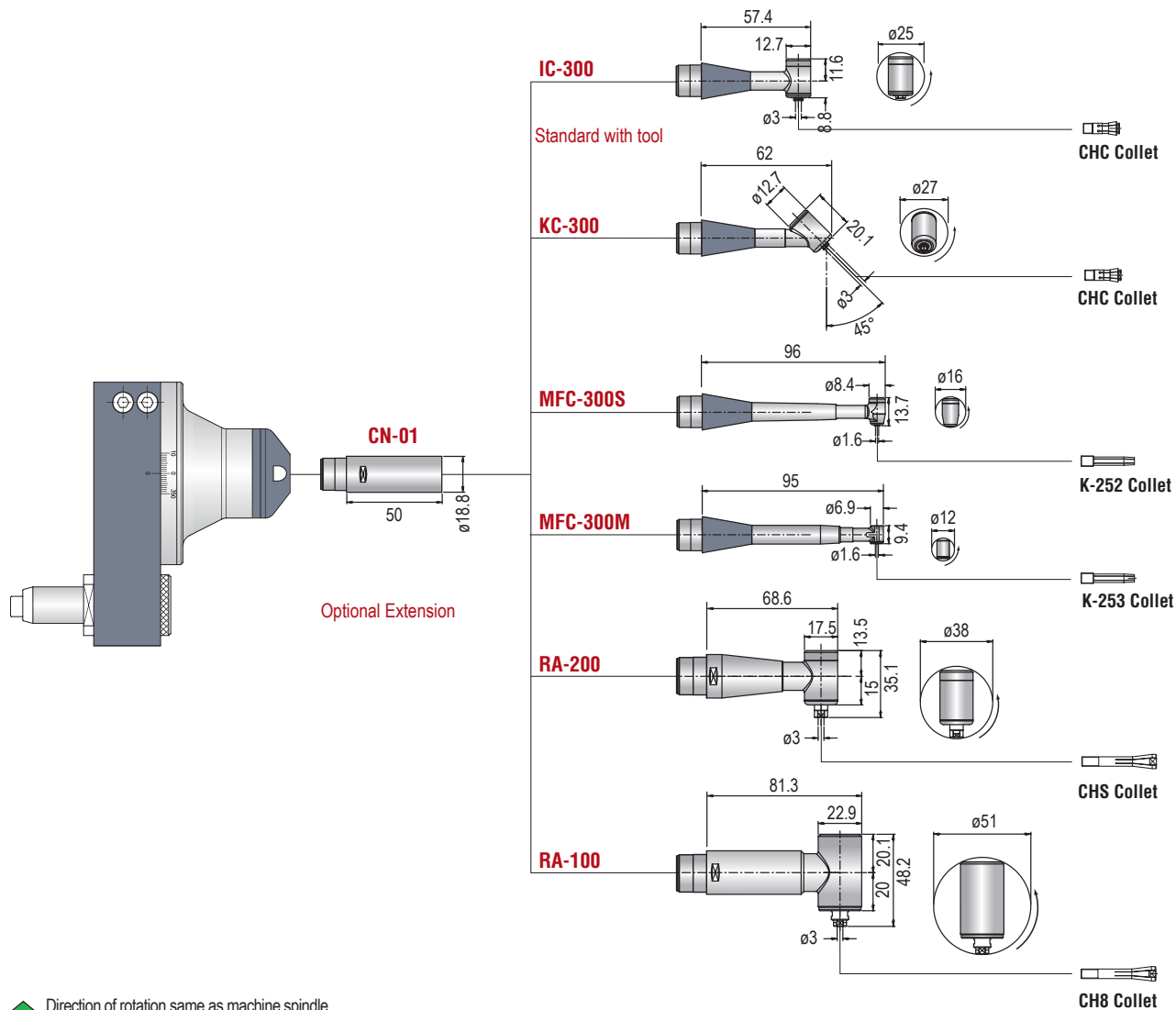

Technical Data

	IC-300	KC-300	MFC-300S	MFC-300M	RA-200	RA-100	CN-01
Ratio	1:1.75	1:1.75	1:1	1:1	1:1.66	1:1.375	1:1
Max. NSK Output RPM	15,000	15,000	15,000	15,000	13,330	7,490	15,000
Torque	.74 ft lbs	.74 ft lbs	.74 ft lbs	.74 ft lbs	2.95 ft lbs	2.95 ft lbs	-
NSK Collet	CHC	CHC	K-252	K-253	CHS	CH8	-

Included with Tool: Storage Case • (1) NSK Tool
(IC-300) • Wrenches • Grease • Instruction Manual

CHC (for IC-300, KC-300)

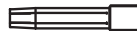

Model	Inside Diameter (mm)
GP-59021-00	1.6
GP-59024-00	2.35
GP-59015-00	3.0
GP-59010-00	3.175

CHS (for RA-200)

Model	Inside Diameter (mm)
GP-59027-00	0.8
GP-59028-00	0.9
GP-59029-00	1.0
GP-59030-00	1.1
GP-59031-00	1.2
GP-59032-00	1.3
GP-59033-00	1.4
GP-59034-00	1.5
GP-59012-00	1.6
GP-59035-00	1.7
GP-59036-00	1.8
GP-59037-00	1.9
GP-59016-00	2.0
GP-59038-00	2.1
GP-59039-00	2.2
GP-59040-00	2.3
GP-59041-00	2.35
GP-59042-00	2.4
GP-59013-00	2.5
GP-59043-00	2.6
GP-59044-00	2.7
GP-59045-00	2.8
GP-59046-00	2.9
GP-59009-00	3.0
GP-59011-00	3.175

CH8 (for RA-100)

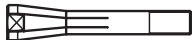
Model	Inside Diameter (mm)
GP-59047-00	0.8
GP-59048-00	0.9
GP-59049-00	1.0
GP-59050-00	1.1
GP-59051-00	1.2
GP-59052-00	1.3
GP-59053-00	1.4
GP-59054-00	1.5
GP-59055-00	1.6
GP-59056-00	1.7
GP-59057-00	1.8
GP-59058-00	1.9
GP-59059-00	2.0
GP-59060-00	2.1
GP-59061-00	2.2
GP-59062-00	2.3
GP-59063-00	2.35
GP-59064-00	2.4
GP-59065-00	2.5
GP-59066-00	2.6
GP-59067-00	2.7
GP-59068-00	2.8
GP-59069-00	2.9
GP-59070-00	3.0
GP-59008-00	3.175

K-252 (for MFC-300S)

Model	Inside Diameter (mm)
GP-59025-00	1.6

K-253 (for MFC-300M)

Model	Inside Diameter (mm)
GP-59026-00	1.6

OPTIONAL STOP BLOCK
